

Chapter 15

ELECTROMAGNETIC INDUCTION

Learning Objectives

At the end of this chapter the students will be able to:

1. Recall that a changing magnetic flux through a circuit causes an emf to be induced in the circuit.
2. Know that the induced emf lasts so long as the magnetic flux keeps changing.
3. Determine Motional emf.
4. Use Faraday's law of electromagnetic induction to determine the magnitude of induced emf.
5. Apply Lenz's law to determine the direction of induced emf.
6. Recognize self and mutual induction.
7. Define mutual inductance, self-inductance and its unit henry.
8. Know and use the formula $E = \frac{1}{2} LI^2$
9. Calculate the energy stored in an inductance.
10. Describe the principle, construction and operation of an AC and DC generator.
11. Describe the principle, construction and operation of DC motor.
12. Recognize back emf in motors and back motor effect in generators.
13. Describe the structure and principle of operation of transformer.
14. Use $\frac{N_s}{N_p} = \frac{V_s}{V_p}$ and $V_p I_p = V_s I_s$ for an ideal transformer.
15. Apply transformer equation to solve the problems.
16. Understand and describe eddy currents and use of laminated core.

As soon as Oersted discovered that electric currents produce magnetic fields, many scientists began to look for the reverse effect, that is, to cause an electric current by means of a magnetic field. In 1831 Michael Faraday in England and at the same time Joseph Henry in USA observed that an emf is set up in a conductor when it moves across a magnetic field. If the moving conductor was connected to a sensitive galvanometer, it would show an electric current flowing through the circuit as long as the conductor is kept moving in the magnetic field. The emf produced in the conductor is called induced emf, and the current generated is called the induced current. This phenomenon is known as electromagnetic induction.

15.1 INDUCED EMF AND INDUCED CURRENT

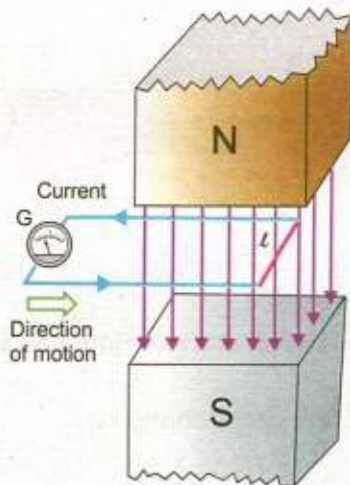

Fig.15.1

There are many ways to produce induced emf. Fig. 15.1 illustrates one of them. Consider a straight piece of wire of length l placed in the magnetic field of a permanent magnet. The wire is connected to a sensitive galvanometer. This forms a closed path or loop without any battery. In the beginning when the loop is at rest in the magnetic field, no current is shown by the galvanometer. If we move the loop from left to right, the length l of the wire is dragged across the magnetic field and a current flows through the loop. As we stop moving the loop, current also stops. Now, if we move the loop in opposite direction, current also reverses its direction. This is indicated by the deflection of the galvanometer in opposite direction.

The induced current depends upon the speed with which conductor moves and upon the resistance of the loop. If we change the resistance of the loop by inserting different resistors in the loop, and move it in the magnetic field with the same speed every time, we find that the product of induced current I and the resistance R of the loop remains constant, i.e.,

$$I \times R = \text{constant}$$

This constant is the induced emf. The induced emf leads to an induced current when the circuit is closed. The current can be increased by

- i) using a stronger magnetic field
- ii) moving the loop faster
- iii) replacing the loop by a coil of many turns

If we perform the above experiment in the other way, i.e., instead of moving the loop across the magnetic field, we keep the loop stationary and move the magnet, then it can be easily observed that the results are the same. Thus, it can be concluded that it is the relative motion of the loop and the magnet that causes the induced emf.

In fact, this relative motion changes the magnetic flux through the loop, therefore, we can say that an induced emf is produced in a loop if the magnetic flux through it changes. The greater the rate of change of flux, the larger is the induced emf.

There are some other methods described below in which an emf is induced in a loop by producing a change of magnetic

flux through it.

1. Fig. 15.2 (a) shows a bar magnet and a coil of wire to which a galvanometer is connected. When there is no relative motion between the magnet and the coil, the galvanometer indicates no current in the circuit. As soon as the bar magnet is moved towards the coil, a current appears in it (Fig 15.2 b). As the magnet is moved, the magnetic flux through the coil changes, and this changing flux produces the induced current in the coil. When the magnet moves away from the coil, a current is again induced but now in opposite direction. The current would also be induced if the magnets were held stationary and the coil is moved.

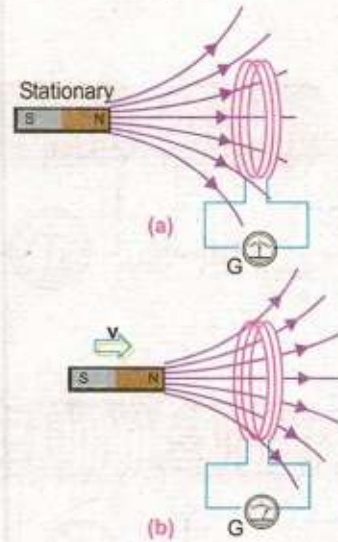

Fig. 15.2

2. There is another method in which the current is induced in a coil by changing the area of the coil in a constant magnetic field. Fig. 15.3 (a) shows that no current is induced in the coil of constant area placed in a constant magnetic field. However, when the coil is being distorted so as to reduce its area, (Fig. 15.3 b) an induced emf and hence current appears. The current vanishes when the area is no longer changing. If the distorted coil is brought to its original circular shape thereby increasing the area, an oppositely directed current is induced which lasts as long as the area is changing.

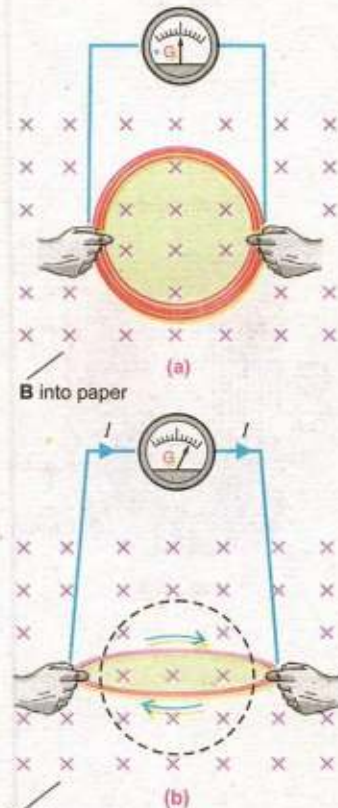

Fig. 15.3

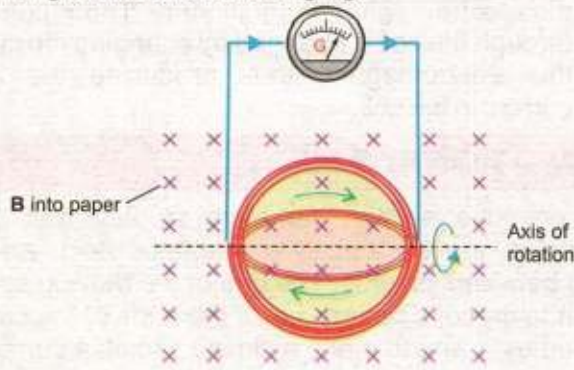

Fig. 15.4

3. An induced current can also be generated when a coil of constant area is rotated in a constant magnetic field. Here, also, the magnetic flux through the coil changes (Fig. 15.4). This is the basic principle used in electric generators.
4. A very interesting method to induce current in a coil involves by producing a change of magnetic flux in

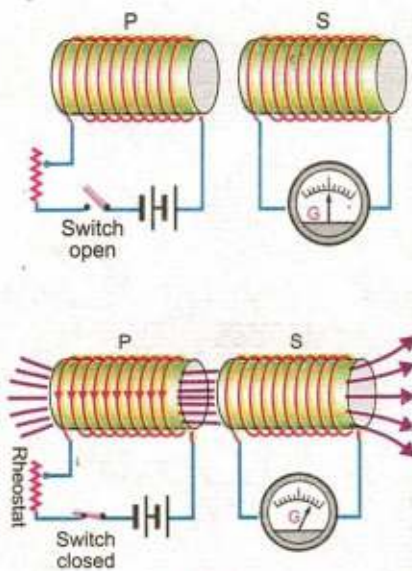

Fig. 15.5

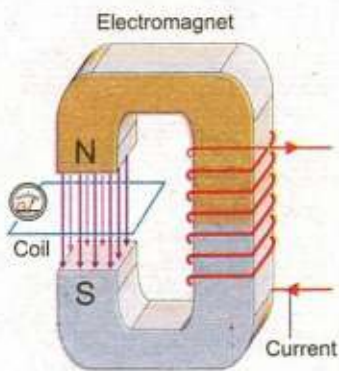

Fig. 15.6

a nearby coil. Fig. 15.5 shows two coils placed side by side. The coil P is connected in series with a battery, a rheostat and a switch, while the other coil S is connected to a galvanometer only. Since there is no battery in the coil S, one might expect that the current through it will always be zero. Now, if the switch of the coil P is suddenly closed, a momentary current is induced in coil S. This is indicated by the galvanometer, which suddenly deflects and then returns to zero. No induced current exists in coil S as long as the current flows steadily in the coil P. An oppositely directed current is induced in the coil S at the instant the switch of coil P is opened. Actually, the current in P grows from zero to its maximum value just after the switch is closed. The current comes down to zero when the switch is opened. Due to change in current, the magnetic flux associated with the coil P changes momentarily. This changing flux is also linked with the coil S that causes the induced current in it. Current in coil P can also be changed with the help of rheostat.

- It is also possible to link the changing magnetic flux with a coil by using an electromagnet instead of a permanent magnet. The coil is placed in the magnetic field of an electromagnet (Fig. 15.6). Both the coil and the electromagnet are stationary. The magnetic flux through the coil is changed by changing the current of the electromagnet, thus producing the induced current in the coil.

15.2 MOTIONAL EMF

In the previous section we have studied that when a conductor is moved across a magnetic field, an emf is induced between its ends. The emf of the moving conductor is similar to that of a battery, i.e., if the ends of the conductor are joined by a wire to make a closed circuit, a current flows through it.

The emf induced by the motion of a conductor across a magnetic field is called motional emf.

Consider a conducting rod of length L placed on two parallel metal rails separated by a distance L . A galvanometer is connected between the ends c and d of the rails. This forms a complete conducting loop abcda (Fig. 15.7a). A uniform

magnetic field \mathbf{B} is applied directed into the page. Initially when the rod is stationary, galvanometer indicates no current in the loop. If the rod is pulled to the right with constant velocity \mathbf{v} , the galvanometer indicates a current flowing through the loop. Obviously, the current is induced due to the motion of the conducting rod across the magnetic field. The moving rod is acting as a source of emf $\epsilon = V_b - V_a = \Delta V$.

When the rod moves, a charge q within the rod also moves with the same velocity \mathbf{v} in the magnetic field \mathbf{B} and experiences a force given by

$$\mathbf{F} = q\mathbf{v} \times \mathbf{B}$$

The magnitude of the force is

$$F = qvB \sin \theta$$

Since angle θ between \mathbf{v} and \mathbf{B} is 90° , so

$$F = qvB$$

Applying the right hand rule, we see that \mathbf{F} is directed from a to b in the rod. As a result the charge migrates to the top end of the conductor. As more and more of the charges migrate, concentration of the charge is produced at the top b and deficiency of charges at the bottom a . This redistribution of charge sets up an electrostatic field \mathbf{E} directed from b to a . The electrostatic force on the charge is $F_e = q\mathbf{E}$ directed from b to a . The system quickly reaches an equilibrium state in which these two forces on the charge are balanced. If E_0 is the electric intensity in this state then

$$qE_0 = qvB$$

$$E_0 = vB \quad \dots\dots\dots (15.1)$$

The motional emf ϵ will be equal to the potential difference $\Delta V = V_b - V_a$ between the two ends of the moving conductor in this equilibrium state. The gradient of potential will be given by $\Delta V/L$. As the electric intensity is given by the negative of the gradient therefore,

$$E_0 = -\frac{\Delta V}{L} \quad \dots\dots\dots (15.2)$$

$$\text{or } \Delta V = -LE_0 = -(LvB)$$

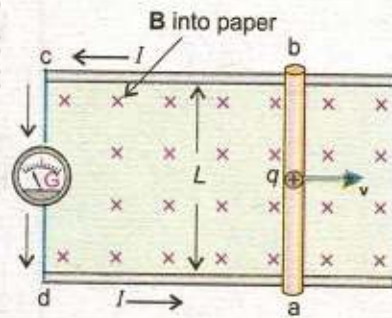

Fig. 15.7 (a)

The motional emf

$$\epsilon = \Delta V = -LvB \quad \dots\dots\dots (15.3)$$

This is the magnitude of motional emf. However, if the angle between v and B is θ , then

$$\epsilon = -vBL \sin\theta \quad \dots\dots\dots (15.4)$$

Due to induced emf positive charges would flow along the path $abcd$, therefore the induced current is anticlockwise in the diagram. As the current flows the quantity of the charge at the top decreases so the electric intensity decreases but the magnetic force remains the same. Hence the equilibrium is disturbed in favour of magnetic force. Thus as the charges reach the end a of the conductor due to current flow, they are carried to the top end b of the conductor by the unbalanced magnetic field and the current continues to flow.

Interesting Information



This heater operates on the principle of electromagnetic induction. The water in the metal pot is boiling whereas that in the glass pot is not. Even the glass top of the heater is cool to touch. The coil just beneath the top carries ac current that produces changing magnetic flux. Flux linking with pots induce emf in them. Current is generated in the metal pot that heats up the water, but no current flows through the glass pan, why?

Example 15.1: A metal rod of length 25 cm is moving at a speed of 0.5 ms^{-1} in a direction perpendicular to a 0.25 T magnetic field. Find the emf produced in the rod.

Solution:

$$\text{Speed of rod} = v = 0.5 \text{ ms}^{-1}$$

$$\text{Length of rod} = L = 25 \text{ cm} = 0.25 \text{ m}$$

$$\text{Magnetic flux density} = B = 0.25 \text{ T} = 0.25 \text{ NA}^{-1} \text{ m}^{-1}$$

$$\text{Induced emf} = \epsilon = ?$$

Using the relation,

$$\epsilon = vBL$$

$$\epsilon = 0.5 \text{ ms}^{-1} \times 0.25 \text{ NA}^{-1} \text{ m}^{-1} \times 0.25 \text{ m}$$

$$\epsilon = 3.13 \times 10^{-2} \text{ JC}^{-1} = 3.13 \times 10^{-2} \text{ V}$$

15.3 FARADAY'S LAW AND INDUCED EMF

The motional emf induced in a rod moving perpendicular to a magnetic field is $\epsilon = -vBL$. The motional emf as well as other induced emfs can be described in terms of magnetic flux. Consider the experiment shown in Fig. 15.8 again. Let the conducting rod L moves from position 1 to position 2 in a small interval of time Δt . The distance travelled by the rod in time Δt is $x_2 - x_1 = \Delta x$

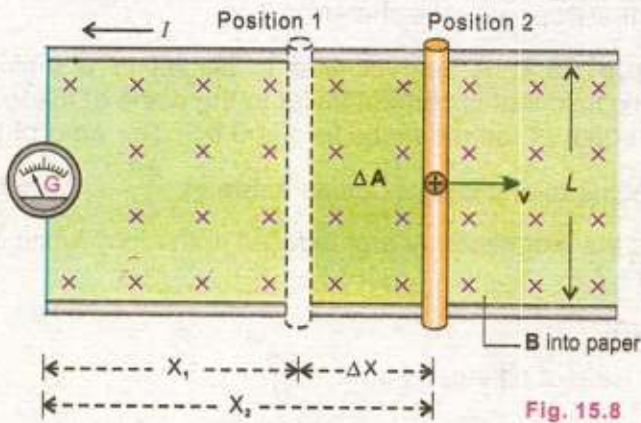

Fig. 15.8

Since the rod is moving with constant velocity v , therefore

$$v = \frac{\Delta x}{\Delta t} \quad \dots\dots\dots (15.5)$$

From Eq.15.3

$$\epsilon = -vBL = -\frac{\Delta x}{\Delta t}BL \quad \dots\dots\dots (15.6)$$

As the rod moves through the distance Δx , the increase in the area of loop is given by $\Delta A = \Delta x.L$. This increases the flux through the loop by $\Delta\Phi = \Delta A.B = \Delta x.L.B$. Putting $\Delta x.L.B = \Delta\Phi$ in Eq.15.6, we get

$$\epsilon = -\frac{\Delta\Phi}{\Delta t} \quad \dots\dots\dots (15.7)$$

If there is a coil of N loops instead of a single loop, then the induced emf will become N times, i.e.,

$$\epsilon = -N\frac{\Delta\Phi}{\Delta t} \quad \dots\dots\dots (15.8)$$

Although the above expression is derived on the basis of motional emf, but it is true in general. This conclusion was first arrived at by Faraday, so this is known as Faraday's law of electromagnetic induction which states that

"The average emf induced in a conducting coil of N loops is equal to the negative of the rate at which the magnetic flux through the coil is changing with time".

Point to Ponder

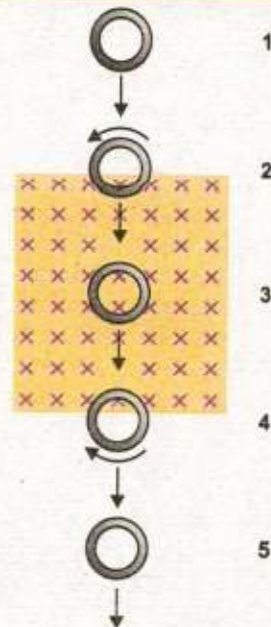

A copper ring passes through a rectangle region where a constant magnetic field is directed into the page. What do you guess about the current in the ring at the positions 2, 3 and 4?

The minus sign indicates that the direction of the induced emf is such that it opposes the change in flux.

Example 15.2: A loop of wire is placed in a uniform magnetic field that is perpendicular to the plane of the loop. The strength of the magnetic field is 0.6 T. The area of the loop begins to shrink at a constant rate of $\frac{\Delta A}{\Delta t} = 0.8 \text{ m}^2\text{s}^{-1}$. What is the magnitude of emf induced in the loop while it is shrinking?

Solution:

$$\text{Rate of change of area} = \frac{\Delta A}{\Delta t} = 0.8 \text{ m}^2\text{s}^{-1}$$

$$\text{Magnetic flux density} = B = 0.6 \text{ T} = 0.6 \text{ NA}^{-1}\text{m}^{-1}$$

$$\text{Number of turns} = N = 1$$

$$\text{Induced emf} = \varepsilon = ?$$

$$\text{Rate of change of flux} = \frac{\Delta\Phi}{\Delta t} = B \frac{\Delta A}{\Delta t} \cos 0^\circ = B \frac{\Delta A}{\Delta t}$$

Applying Faraday's Law, magnitude of induced emf

$$\varepsilon = N \frac{\Delta\Phi}{\Delta t} = NB \frac{\Delta A}{\Delta t}$$

$$= 1 \times 0.6 \text{ NA}^{-1}\text{m}^{-1} \times 0.8 \text{ m}^2\text{s}^{-1}$$

$$\varepsilon = 0.48 \text{ JC}^{-1} = 0.48 \text{ V}$$

15.4 LENZ'S LAW AND DIRECTION OF INDUCED EMF

In the previous section, a mathematical expression of the Faraday's law of electromagnetic induction was derived as

$$\varepsilon = -N \frac{\Delta\Phi}{\Delta t}$$

The minus sign in the expression is very important. It has to do with the direction of the induced emf. To determine the direction we use a method based on the discovery made by the Russian Physicist Heinrich Lenz in 1834. He found that the polarity of an induced emf always leads to an induced current that opposes, through the magnetic field of the induced current, the change inducing the emf. The rule is known as Lenz's law which states that

"The direction of the induced current is always so as to oppose the change which causes the current".

The Lenz's law refers to induced currents and not to induced emf, which means that we can apply it directly to closed conducting loops or coils. However, if the loop is not closed we can imagine as if it were closed, and then from the direction of induced current, we can find the direction of the induced emf.

Let us apply the Lenz's law to the coil in which current is induced by the movement of a bar magnet. We know that a current carrying coil produces a magnetic field similar to that of a bar magnet. One face of the coil acts as the north pole while the other one as the south pole. If the coil is to oppose the motion of the bar magnet, the face of the coil towards the magnet must become a north pole (Fig. 15.9). The two north poles will then repel each other. The right hand rule applied to

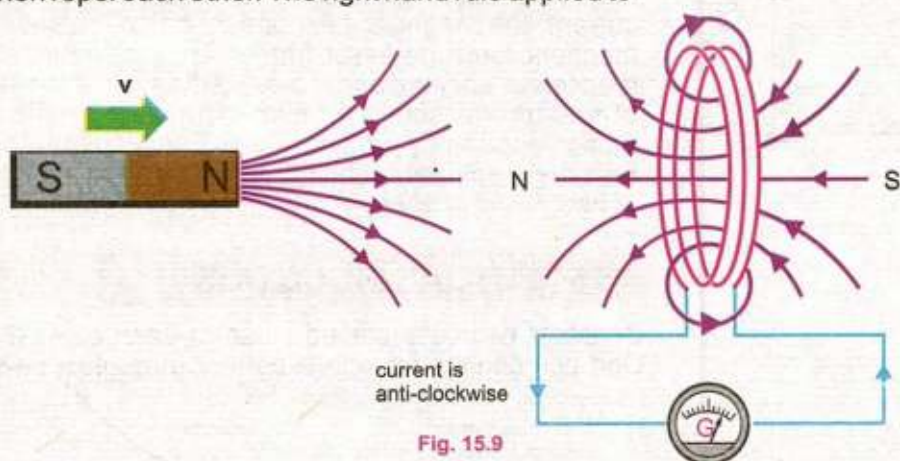

Fig. 15.9

the coil suggests that the induced current must be anti-clockwise as seen from the side of the bar magnet.

According to Lenz's law the "push" of the magnet is the "change" that produces the induced current, and the current acts to oppose the push. On the other hand if we pull the magnet away from the coil the induced current will oppose the "pull" by creating a south pole on the face of coil towards the bar magnet.

The Lenz's law is also a statement of law of conservation of energy that can be conveniently applied to the circuits involving induced currents. To understand this, consider once again the experiment in Fig. 15.8. When the rod moves towards right, emf is induced in it and an induced current flows through the loop in the anti-clockwise direction. Since the

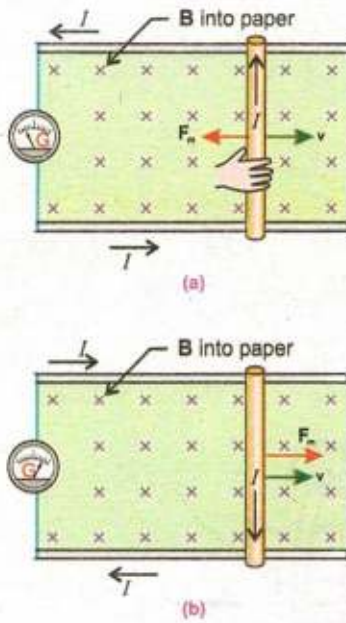

Fig. 15.10

current carrying rod is moving in the magnetic field, it experiences a magnetic force F_m having the magnitude $F_m = ILB\sin 90^\circ$. By right hand rule the direction of F_m is opposite to that of v , so it tends to stop the rod (Fig. 15.10 a). An external dragging force equal to F_m in magnitude but opposite in direction must be applied to keep the rod moving with constant velocity. This dragging force provides the energy for the induced current to flow. This energy is the source of induced current, thus electromagnetic induction is exactly according to law of conservation of energy.

The Lenz's law forbids the induced current directed clockwise in this case, because the force F_m would be, then, in the direction of v that would accelerate the rod towards right (Fig. 15.10 b). This in turn would induce a stronger current, the magnetic field due to it also increases, and the magnetic force increases further. Thus the motion of the wire is accelerated more and more. Starting with a minute quantity of energy, we obtain an ever increasing kinetic energy of motion apparently from nowhere. Consequently the process becomes self-perpetuating which is against the law of conservation of energy.

15.5 MUTUAL INDUCTION

Consider two coils placed close to each other (Fig.15.11). One coil connected with a battery through a switch and a

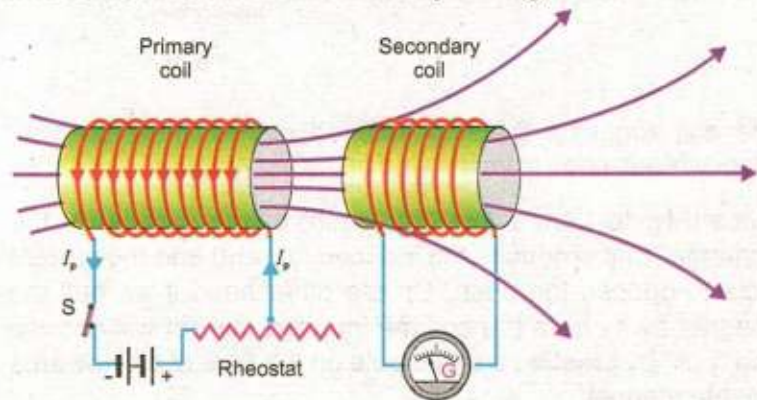

Fig. 15.11

rheostat is called the "primary" and the other one connected to the galvanometer is called the "secondary". If the current in the primary is changed by varying the resistance of the rheostat, the magnetic flux in the surrounding region

changes. Since the secondary coil is in the magnetic field of the primary, the changing flux also links with the secondary. This causes an induced emf in the secondary.

The phenomenon in which a changing current in one coil induces an emf in another coil is called the mutual induction.

According to Faraday's law, the emf induced in the secondary coil is proportional to the rate of change of flux

$$\frac{\Delta\Phi_s}{\Delta t} \text{ passing through it, i.e., } \epsilon_s = -N_s \frac{\Delta\Phi_s}{\Delta t}$$

where N_s is the number of turns in the secondary coil.

Let the flux passing through one loop of the secondary coil be Φ_s . Net flux passing through the coil of N_s loops is $N_s\Phi_s$. As this flux is proportional to the magnetic field produced by the current I_p in the primary and the magnetic field itself is proportional to I_p , therefore

$$N_s\Phi_s \propto I_p$$

$$N_s\Phi_s = MI_p \quad \dots\dots\dots (15.9)$$

Where $M = \frac{N_s\Phi_s}{I_p}$ is proportionality constant called the

mutual inductance of the two coils. It depends upon the number of turns of the coils, their area of cross-section, their closeness together and the nature of the core material upon which the two coils are wound.

By Faraday's law the emf induced in the secondary coil is given by the rate of change of flux through the secondary.

$$\epsilon_s = -N_s \frac{\Delta\Phi_s}{\Delta t} = -\frac{\Delta(N_s\Phi_s)}{\Delta t}$$

Putting $N_s\Phi_s = MI_p$ from Eq.15.9

$$\epsilon_s = -\frac{\Delta(MI_p)}{\Delta t}$$

$$\epsilon_s = -M \frac{\Delta I_p}{\Delta t} \quad \dots\dots\dots (15.10)$$

The Eq.15.10 shows that the emf induced in the secondary is proportional to the time rate of change of current in the primary.

The negative sign in Eq.15.10 indicates the fact that the induced emf is in such a direction that it opposes the change of current in the primary coil. While finding out the value of M from Eq.15.10, negative sign is ignored. Thus M may be defined as the ratio of average emf induced in the secondary to the time rate of change of current in the primary.

$$M = \frac{\epsilon_s}{\frac{\Delta I_p}{\Delta t}}$$

The SI unit for the mutual inductance M is Vs A^{-1} , which is called as henry (H) after Joseph Henry.

One henry is the mutual inductance of the pair of coils in which the rate of change of current of one ampere per second in the primary causes an induced emf of one volt in the secondary.

Example 15.3: An emf of 5.6 V is induced in a coil while the current in a nearby coil is decreased from 100 A to 20 A in 0.02 s. What is the mutual inductance of the two coils? If the secondary has 200 turns, find the change in flux during this interval.

Solution:

emf induced in the secondary = $\epsilon_s = 5.6 \text{ V}$
 Change in current in primary = $\Delta I_p = 100 \text{ A} - 20 \text{ A} = 80 \text{ A}$
 Time interval for the change = $\Delta t = 0.02 \text{ s}$
 Mutual inductance = $M = ?$
 No. of turns in the secondary = $N_s = 200$
 Change in flux = $\Delta \Phi = ?$

Using $\epsilon_s = \frac{\Delta I_p}{\Delta t} M$

$$5.6 \text{ V} = M \times \frac{80 \text{ A}}{0.02 \text{ s}}$$

$$M = \frac{5.6 \text{ V} \times 0.02 \text{ s}}{80 \text{ A}} = 1.4 \times 10^{-3} \text{ VsA}^{-1}$$

By Faraday's Law $\epsilon_s = N_s \frac{\Delta \Phi}{\Delta t}$

$$\Delta \Phi_s = \frac{\epsilon_s \Delta t}{N_s} = \frac{5.6 \text{ V} \times 0.02 \text{ s}}{200} = 5.6 \times 10^{-4} \text{ Wb}$$

15.6 SELF INDUCTION

According to Faraday's law, the change of flux through a coil by any means induces an emf in it. In all the examples we have discussed so far, induced emf was produced by a changing magnetic flux from some external source. But the change of flux through a coil may also be due to a change of current in the coil itself.

Consider the circuit shown in Fig. 15.12. A coil is connected in series with a battery and a rheostat. Magnetic flux is produced through the coil due to current in it. If the current is changed by varying the rheostat quickly, magnetic flux through the coil changes that causes an induced emf in the coil. Such an emf is called as self induced emf.

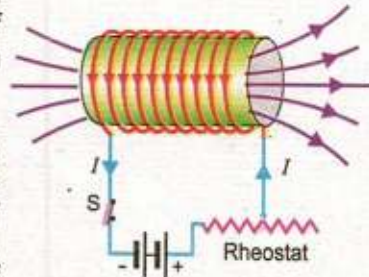

Fig. 15.12

The phenomenon in which a changing current in a coil induces an emf in itself is called self induction.

If the flux through one loop of the coil be Φ , then the total flux through the coil of N turns would be $N\Phi$. As Φ is proportional to the magnetic field which is in turn proportional to the current I , therefore

$$N\Phi \propto I$$

or $N\Phi = LI$ (15.11)

where $L = \frac{N\Phi}{I}$ is the constant of proportionality called the self inductance of the coil. It depends upon the number of turns of the coil, its area of cross-section and the core material. By winding the coil around a ferromagnetic (iron) core, the magnetic flux and hence the inductance can be increased significantly relative to that for an air core.

By Faraday's Law, emf induced in the coil is

$$\begin{aligned} \epsilon_L &= -N \frac{\Delta\Phi}{\Delta t} \\ \epsilon_L &= - \frac{\Delta(N\Phi)}{\Delta t} \end{aligned}$$

Putting $N\Phi = LI$ from Eq.15.11

$$\epsilon_L = - \frac{\Delta(LI)}{\Delta t}$$

or $\epsilon_L = -L \frac{\Delta I}{\Delta t}$ (15.12)

The Eq.15.12 shows that the self induced emf in a coil is proportional to the time rate of change of current in the coil. Self inductance L of a coil may be defined as the ratio of the emf to the rate of change of current in the coil. The unit of L is also henry (H).

The negative sign in Eq.15.12 indicates that the self induced emf must oppose the change that produced it. That is why the self induced emf is sometimes called as back emf. This is exactly in accord with the Lenz's law. If the current is increased, the induced emf will be opposite to that of battery and if the current is decreased the induced emf will aid, rather than opposing the battery. Because of their self inductance, coils of wire are known as inductors, and are widely used in electronics. In alternating current, inductors behave like resistors.

Example 15.4: The current in a coil of 1000 turns is changed from 5 A to zero in 0.2 s. If an average emf of 50 V is induced during this interval, what is the self inductance of the coil? What is the flux through each turn of the coil when a current of 6 A is flowing?

Solution:

$$\text{Change in current} = \Delta I = 5\text{ A} - 0 = 5\text{ A}$$

$$\text{Time interval} = \Delta t = 0.2\text{ s}$$

$$\text{emf induced} = \varepsilon = 50\text{ V}$$

$$\text{Self induction} = L = ?$$

$$\text{Steady current} = I = 6\text{ A}$$

$$\text{No. of turns of coil} = N = 1000$$

$$\text{Flux through each turn} = \Phi = ?$$

$$\text{Using } L = \frac{\varepsilon}{\frac{\Delta I}{\Delta t}} = \frac{50\text{ V}}{\frac{5\text{ A}}{0.2\text{ s}}} = \frac{50\text{ V}}{5\text{ A}/0.2\text{ s}}$$

$$L = 2\text{ VsA}^{-1} = 2\text{ H}$$

Now, using Eq.15.11

$$N\Phi = LI \quad \text{or} \quad \Phi = \frac{LI}{N}$$

$$\Phi = \frac{2\text{ H} \times 6\text{ A}}{1000} = 1.2 \times 10^{-2}\text{ Wb}$$

15.7 ENERGY STORED IN AN INDUCTOR

We have studied in chapter 12 that energy can be stored in the electric field between the plates of a capacitor. In a similar manner, energy can be stored in the magnetic field of an inductor.

Consider a coil connected to a battery and a switch in series (Fig. 15.13). When the switch is turned on voltage V is applied across the ends of the coil and current through it rises from zero to its maximum value I . Due to change of current, an emf is induced, which is opposite to that of battery. Work is done by the battery to move charges against the induced emf.

Work done by the battery in moving a small charge Δq is

$$W = \Delta q \varepsilon_L \dots\dots\dots (15.13)$$

where ε_L is the magnitude of induced emf, given by

$$\varepsilon_L = L \frac{\Delta I}{\Delta t}$$

Putting the value of ε_L in Eq. 15.13 we get

$$W = \Delta q \cdot L \frac{\Delta I}{\Delta t} = \frac{\Delta q}{\Delta t} \cdot L \Delta I \dots\dots\dots (15.14)$$

Total work done in establishing the current from 0 to I is found by inserting for $\frac{\Delta q}{\Delta t}$, the average current, and the value of ΔI .

$$\text{Average current} = \frac{\Delta q}{\Delta t} = \frac{0 + I}{2} = \frac{1}{2} I$$

$$\text{Change in current} = \Delta I = I - 0 = I$$

$$\text{Total work } W = \left(\frac{1}{2} I\right) L I$$

$$W = \frac{1}{2} L I^2$$

This work is stored as potential energy in the inductor. Hence the energy stored in an inductor is

$$U_m = \frac{1}{2} L I^2 \dots\dots\dots (15.15)$$

As in case of a capacitor, energy is stored in the electric field between the plates, likewise, in an inductor, energy is stored in the magnetic field. Therefore, Eq. 15.15 can be expressed in terms of the magnetic field \mathbf{B} of a solenoid which has n turns per unit length and area of cross section \mathbf{A} . The magnetic field strength inside it is $B = \mu_0 n I$. Since flux through the coil is

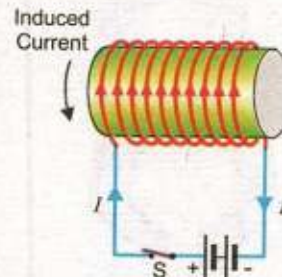
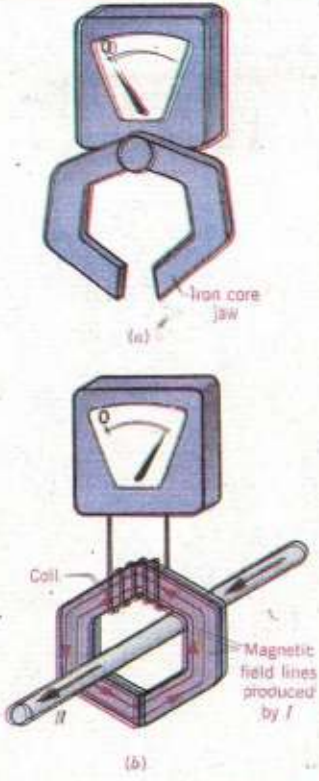

Fig. 15.13

For Your Information



An induction ammeter with its iron-core jaw (a) open and (b) closed around a wire carrying an alternating current I . Some of the magnetic field lines that encircle the wire are routed through the coil by the iron core and lead to an induced emf. The meter detects the emf and is calibrated to display the amount of current in the wire.

$$\Phi = BA$$

or $\Phi = \mu_0 nIA$ (15.16)

Substituting the value of Φ in Eq.15.11

$$N\Phi = LI \quad \text{or} \quad L = \frac{N\Phi}{I}$$

we have $L = N \frac{\mu_0 nIA}{I} = N \mu_0 nA$

If l is the length of solenoid, then putting $N = nl$ in above Eq. we get the self inductance of the solenoid as

$$L = (nl) \mu_0 nA$$

$$L = \mu_0 n^2 Al$$
 (15.17)

Substituting for L , the Eq.15.15 becomes,

$$U_m = \frac{1}{2} (\mu_0 n^2 Al) I^2$$
 (15.18)

Since B for a solenoid is given by $B = \mu_0 nI$ or $I = \frac{B}{\mu_0 n}$

Substituting for I , Eq.15.18 becomes

$$U_m = \frac{1}{2} (\mu_0 n^2 Al) \left(\frac{B}{\mu_0 n} \right)^2$$

$$U_m = \frac{1}{2} \frac{B^2}{\mu_0} (Al)$$
 (15.19)

Now energy density can be defined as the energy stored per unit volume inside the solenoid, so dividing Eq.15.19 by the volume (Al), we get energy density,

$$u_m = \frac{1}{2} \frac{B^2}{\mu_0}$$
 (15.20)

Example 15.5: A solenoid coil 10.0 cm long has 40 turns per cm. When the switch is closed, the current rises from zero to its maximum value of 5.0 A in 0.01 s. Find the energy stored in the magnetic field if the area of cross-section of the solenoid be 28 cm².

Solution:

Length of solenoid = $l = 10.0 \text{ cm} = 0.1 \text{ m}$

No. of turns = $n = 40 \text{ per cm} = 4000 \text{ per m}$

$$\text{Area of cross section} = A = 28 \text{ cm}^2 = 2.8 \times 10^{-3} \text{ m}^2$$

$$\text{Steady current} = I = 5 \text{ A}$$

$$\text{Energy Stored} = U_m = ?$$

First, we calculate the inductance L using the Eq. (15.17)

$$L = \mu_0 n^2 A \ell$$

$$= (4\pi \times 10^{-7}) \text{ WbA}^{-1}\text{m}^{-1} \times (4000 \text{ m}^{-1})^2 \times 2.8 \times 10^{-3} \text{ m}^2 \times 0.1 \text{ m}$$

$$= 5.63 \times 10^{-3} \text{ WbA}^{-1} = 5.63 \times 10^{-3} \text{ H}$$

$$\text{Energy stored} = U_m = \frac{1}{2} L I^2 = \frac{1}{2} (5.63 \times 10^{-3} \text{ NmA}^{-2}) \times (5 \text{ A})^2$$

$$= 7.04 \times 10^{-2} \text{ Nm} = 7.04 \times 10^{-2} \text{ J}$$

15.8 ALTERNATING CURRENT GENERATOR

We have learnt that when a current carrying coil is placed in a magnetic field, a torque acts on it that rotates the coil. What happens if a coil of wire is rotated in a magnetic field? Can a current be produced in the coil? Yes, it does. Such a device is called a current generator.

A current generator is a device that converts mechanical energy into electrical energy.

The principle of an electric generator is based on Faraday's law of electromagnetic induction. When a coil is rotated in a magnetic field by some mechanical means, magnetic flux through the coil changes, and consequently an emf is induced in the coil.

If the generator is connected to an external circuit, an electric current is the output of the generator.

Let a rectangular loop of wire of area A be placed in a uniform magnetic field \mathbf{B} (Fig.15.14). The loop is rotated about z-axis through its centre at constant angular velocity ω . One end of the loop is attached to a metal ring R and the other end to the ring R' . These rings, called the slip rings are concentric with the axis of the loop and rotate with it. Rings $R R'$ slide against stationary carbon brushes to which external circuit is connected.

To calculate the induced emf in the loop, consider its position (Fig.15.15) while it is rotating anticlockwise. The figure shows the top view of the coil. The vertical side ab of the loop is moving with velocity \mathbf{v} in the magnetic field \mathbf{B} . If the angle between \mathbf{v} and \mathbf{B} be θ , the motional emf induced in the side ab has the magnitude,

$$\varepsilon_{ab} = vBL \sin\theta$$

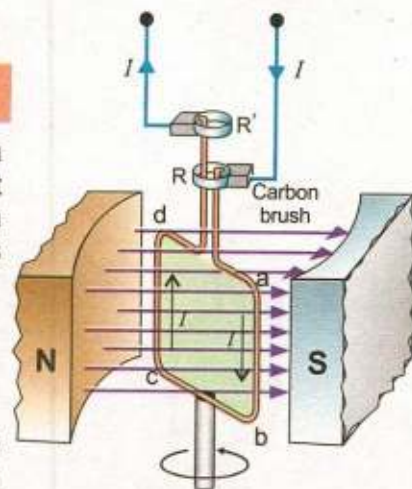

(Front view)

Fig.15.14

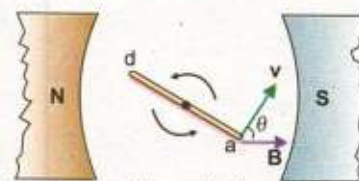

(Top view)

Fig. 15.15

The direction of induced current in the wire ab is the same as that of force F experienced by the charges in the wire, i.e., from top to the bottom. The same amount of emf is induced in the side cd but the direction of current is from bottom to the top.

Therefore $\epsilon_{cd} = vBL \sin \theta$

The net contribution to emf by sides bc and da is zero because the force acting on the charges inside bc and da is not along the wire.

Thus $\epsilon_{bc} = \epsilon_{da} = 0$

Since both the emfs in the sides ab and cd drive current in the same direction around the loop, the total emf in the loop is

$$\epsilon = \epsilon_{ab} + \epsilon_{cd}$$

$$\epsilon = vBL \sin \theta + vBL \sin \theta$$

$$\epsilon = 2vBL \sin \theta$$

If the loop is replaced by a coil of N turns, the total emf in the coil will be,

$$\epsilon = 2NvBL \sin \theta \quad \dots\dots\dots (15.21)$$

The linear speed v of the vertical wire is related to the angular speed ω by the relation

$$v = \omega r$$

where r is the distance of the vertical wires from the centre of the coil. Substituting ωr for v in Eq. (15.21)

We get

$$\epsilon = 2N(\omega r)BL \sin \theta$$

$$\epsilon = N\omega(2rL)B \sin \theta$$

$$\epsilon = N\omega AB \sin \theta \quad \dots\dots\dots (15.22)$$

where $A = 2rL =$ area of the coil

As the angular displacement $\theta = \omega t$, so the Eq. 15.22 becomes

$$\epsilon = N\omega AB \sin(\omega t) \quad \dots\dots\dots (15.23)$$

Eq. 15.23 shows that the induced emf varies sinusoidally with time.

It has the maximum value ϵ_0 when $\sin(\omega t)$ is equal to 1. Thus

$$\epsilon_0 = N\omega AB \quad \dots\dots\dots (15.24)$$

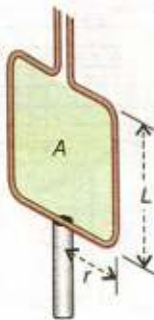

The Eq.15.23 can be written as,

$$\epsilon = \epsilon_0 \sin(\omega t) \quad \dots\dots\dots (15.25)$$

If R is the resistance of the coil, then by Ohm's law, induced current in the coil will be

$$I = \frac{\epsilon}{R} = \frac{\epsilon_0 \sin(\omega t)}{R} = \frac{\epsilon_0}{R} \sin(\omega t)$$

or $I = I_0 \sin(\omega t) \quad \dots\dots\dots (15.26)$

where I_0 is maximum current.

Angular speed ω of the coil is related to its frequency of rotation f as, $\omega = 2\pi f$

The Eqs.15.25 and 15.26 can be written as

$$\epsilon = \epsilon_0 \sin(2\pi f t) \quad \dots\dots\dots (15.27)$$

$$I = I_0 \sin(2\pi f t) \quad \dots\dots\dots (15.28)$$

Eq.15.28 indicates the variation of current as a function of $\theta = 2\pi f t$. Fig. 15.16 shows the graph for the current corresponding to different positions of one loop of the coil.

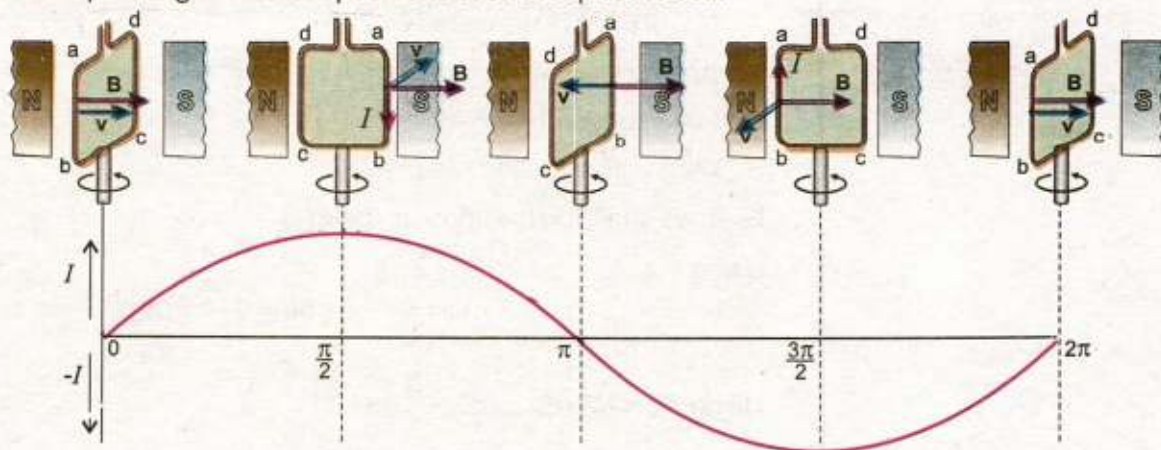

Fig. 15.16

When the angle between \mathbf{v} & \mathbf{B} is $\theta = 0^\circ$, the plane of the loop is perpendicular to \mathbf{B} , current is zero. As θ increases, current also increases and at $\theta = 90^\circ = \pi/2$ rad, the loop is parallel to \mathbf{B} , current is maximum, directed along abcda. On further increase in θ current decreases, and at $\theta = 180^\circ = \pi$ rad the current becomes zero as the loop is again perpendicular to \mathbf{B} . For $180^\circ < \theta < 270^\circ$ current increases but reverses its direction as is clear from the figure. Current is now directed along dcbad. At $\theta = 270^\circ = 3\pi/2$ rad, current is maximum in

For Your Information



Faraday's homopolar generator with which he was able to produce a continuous induced current.

the reverse direction as the loop is parallel to \mathbf{B} . At $\theta = 360^\circ = 2\pi$ rad, one rotation is completed, the loop is perpendicular to \mathbf{B} and the current decreases to zero. After one rotation the cycle repeats itself. The current alternates in direction once in one cycle. Therefore, such a current is called the alternating current. It reverses its direction f times per second.

In actual practice a number of coils are wound around an iron cylinder which is rotated in the magnetic field. This assembly is called an armature. The magnetic field is usually provided by an electromagnet. Armature is rotated by a fuel engine or a turbine run by a waterfall. In some commercial generators, field magnet is rotated around a stationary armature.

Example 15.6: An alternating current generator operating at 50 Hz has a coil of 200 turns. The coil has an area of 120 cm^2 . What should be the magnetic field in which the coil rotates in order to produce an emf of maximum value of 240 volts?

Solution:

$$\text{Frequency of rotation} = f = 50 \text{ Hz}$$

$$\text{No. of turns of the coil} = N = 200$$

$$\text{Area of the coil} = A = 120 \text{ cm}^2 = 1.2 \times 10^{-2} \text{ m}^2$$

$$\text{Maximum emf} = \epsilon_{\text{max}} = 240 \text{ V}$$

$$\text{Magnetic flux density} = B = ?$$

First, we shall find the angular speed ω .

$$\begin{aligned} \text{Using } \omega &= 2\pi f \\ \omega &= 2 \times \frac{22}{7} \times 50 = 314.3 \text{ rad s}^{-1} \end{aligned}$$

$$\text{Using } \epsilon_o = N\omega AB \quad \text{or} \quad B = \frac{\epsilon_o}{N\omega A}$$

$$B = \frac{240 \text{ V}}{200 \times 314.3 \text{ rad s}^{-1} \times 1.2 \times 10^{-2} \text{ m}^2}$$

$$B = 0.32 \text{ Vs rad}^{-1} \text{ m}^{-2} = 0.32 \text{ T}$$

15.9 D.C. GENERATOR

Alternating current generators are not suitable for many applications, for example, to run a D.C. Motor. In 1834, William Sturgeon invented a simple device called a commutator that prevents the direction of current from

changing. Therefore a D.C. generator is similar to the A.C. generator in construction with the difference that "slip rings" are replaced by "split rings". The "split rings" are two halves of a ring that act as a commutator. Fig. 15.17 shows the "split rings" A and A' attached to the two ends of the coil that rotates in the magnetic field. When the current in the coil is zero and is about to change direction, the split rings also change the contacts with the carbon brushes BB'. In this way the output from BB' remains in the same direction, although the current is not constant in magnitude. The curve of the current is shown in Fig. 15.18. It is similar to a sine curve with the lower half inverted. The fluctuations of the output can be significantly reduced by using many coils rather than a single one. Multiple coils are wound around a cylindrical core to form the armature. Each coil is connected to a separate commutator and the output of every coil is tapped only as it reaches its peak emf. Thus the emf in the outer circuit is almost constant.

15.10 BACK MOTOR EFFECT IN GENERATORS

A generator is the source of electricity production. Practically, the generators are not so simple as described above. A large turbine is turned by high pressure steam or waterfall. The shaft of the turbine is attached to the coil which rotates in a magnetic field. It converts the mechanical energy of the driven turbine to electrical energy. The generator supplies current to the external circuit. The devices in the circuit that consume electrical energy are known as the "load". The greater the load the larger the current is supplied by the generator. When the circuit is open, the generator does not supply electrical energy, and a very little force is needed to rotate the coil. As soon as the circuit is closed, a current is drawn through the coil. The magnetic field exerts force on the current carrying coil. Fig. 15.19 shows the forces acting on the coil. Force F_1 is acting on the left side of the coil whereas an equal but opposite force F_2 acts on the right side of the coil. These forces are such that they produce a counter torque that opposes the rotational motion of the coil. This effect is sometimes referred to as back motor effect in the generators. The larger the current drawn, the greater is the counter torque produced. That means more mechanical energy is required to keep the coil rotating with constant angular speed. This is in agreement with the law of conservation of energy. The

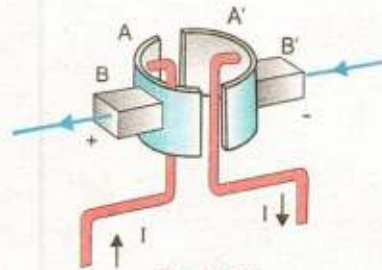

Fig. 15.17

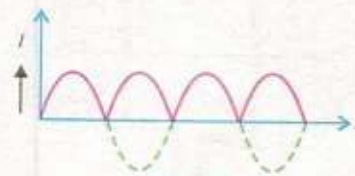
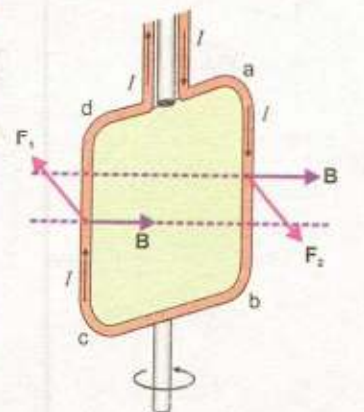
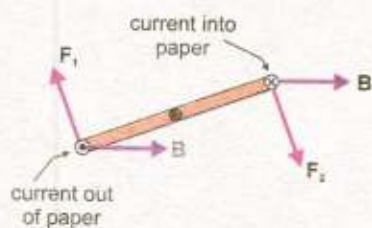

Fig. 15.18



(a) Front view



(b) Top view

Fig. 15.19

energy consumed by the "load" must come from the "energy source" used to drive the turbine.

15.11 D.C. MOTOR

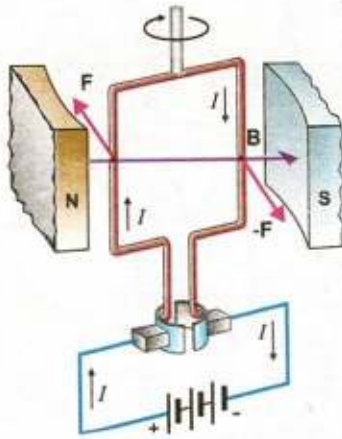

Fig. 15.20

A motor is a device which converts electrical energy into mechanical energy. We already know that a wire carrying current placed in a magnetic field experiences a force. This is the basic principle of an electric motor. In construction a D.C motor is similar to a D.C generator, having a magnetic field, a commutator and an armature. In the generator, the armature is rotated in the magnetic field and current is the output. In the D.C motor, current passes through the armature that rotates in the magnetic field. In the D.C motor, the brushes are connected to a D.C supply or battery (Fig.15.20). When current flows through the armature coil, the force on the conductors produces a torque, that rotates the armature. The amount of this torque depends upon the current, the strength of the magnetic field, the area of the coil and the number of turns of the coil.

If the current in the coil were all the time in the same direction, the torque on it would be reversed after each half revolution. But at this moment, commutator reverses the direction of current that keeps the torque always in the same sense. A little problem arises due to the use of commutator, that is, the torque vanishes each time the current changes its direction. This creates jerks in the smooth running of the armature. However the problem is overcome by using more than one coil wrapped around a soft-iron core. This results in producing a more steady torque.

The magnetic field in the motor, is provided by a permanent magnet or an electromagnet. The windings of the electromagnet are usually called the field coils. The field coils may be in series or in parallel to the armature coils.

15.12 BACK EMF EFFECT IN MOTORS

A motor is just like a generator running in reverse. When the coil of the motor rotates across the magnetic field by the applied potential difference V , an emf ϵ is induced in it. The induced emf is in such a direction that opposes the emf running the motor. Due to this reason the induced emf is called back emf of the motor. The magnitude of the back emf increases with the speed of motor.

Since V and ϵ are opposite in polarity, the net emf in the circuit is $V - \epsilon$. If R is the resistance of the coil and I the current drawn

by the motor, then by Ohm's law

$$I = \frac{V - \varepsilon}{R} \quad \text{or} \quad V = \varepsilon + IR \quad \dots\dots\dots (15.29)$$

When the motor is just started, back emf is almost zero and hence a large current passes through the coil. As the motor speeds up, the back emf increases and the current becomes smaller and smaller. However, the current is sufficient to provide torque on the coil to drive the load and to overcome losses due to friction. If the motor is overloaded, it slows down. Consequently, the back emf decreases and allows the motor to draw more current. If the motor is overloaded beyond its limits, the current could be so high that it may burn out the motor.

Example 15.7: A permanent magnet D.C motor is run by a battery of 24 volts. The coil of the motor has a resistance of 2 ohms. It develops a back emf of 22.5 volts when driving the load at normal speed. What is the current when motor just starts up? Also find the current when motor is running at normal speed.

Solution:

$$\text{Operation Voltage} = V = 24 \text{ V}$$

$$\text{Resistance of the coil} = R = 2 \Omega$$

$$\text{Back emf} = \varepsilon = 22.5 \text{ V}$$

$$\text{Current} = I = ?$$

i) when motor just starts up, the back emf $\varepsilon = 0$

$$\text{Using} \quad V = \varepsilon + IR$$

$$24 \text{ V} = 0 + I \times 2 \Omega$$

$$I = \frac{24 \text{ V}}{2 \Omega} = 12 \text{ V} \Omega^{-1} = 12 \text{ A}$$

when motor runs at normal speed, $\varepsilon = 22.5 \text{ V}$

$$\text{then using} \quad V = \varepsilon + IR$$

$$V = 22.5 \text{ V} + I \times 2 \Omega$$

$$I = \frac{24 \text{ V} - 22.5 \text{ V}}{2 \Omega} = 0.75 \text{ V} \Omega^{-1} = 0.75 \text{ A}$$

15.13 TRANSFORMER

A transformer is an electrical device used to change a given alternating emf into a larger or smaller alternating emf. It

works on the principle of mutual induction between two coils.

In principle, the transformer consists of two coils of copper, electrically insulated from each other, wound on the same iron core. The coil to which A.C power is supplied is called primary and that from which power is delivered to the circuit is called the secondary.

It should be noted that there is no electrical connection between the two coils but they are magnetically linked. Suppose that an alternating emf is applied to the primary. If at some instant t the flux in the primary is changing at the rate of $\Delta\Phi/\Delta t$ then there will be back emf induced in the primary which will oppose the applied voltage. The instantaneous value of the self induced emf is given by

$$\text{Self induced emf} = -N_p \left[\frac{\Delta\Phi}{\Delta t} \right]$$

If the resistance of the coil is negligible then the back emf is equal and opposite to applied voltage V_p ,

$$V_p = -\text{back emf} = N_p \left[\frac{\Delta\Phi}{\Delta t} \right] \dots\dots\dots (15.30)$$

where N_p is the number of turns in the primary.

Assuming the flux through the primary also passes through the secondary, i.e., the two coils are tightly coupled, the rate of change of flux in the secondary will also be $\Delta\Phi/\Delta t$ and the magnitude of the induced emf across the secondary is given by

$$V_s = N_s \left[\frac{\Delta\Phi}{\Delta t} \right] \dots\dots\dots (15.31)$$

where N_s is the number of turns in the secondary

Dividing Eq.15.31 by Eq. 15.30, we get

$$\frac{V_s}{V_p} = \frac{N_s}{N_p} \dots\dots\dots (15.32)$$

If $N_s > N_p$ then according to Eq. 15.32, $V_s > V_p$, such a transformer in which voltage across secondary is greater than the primary voltage is called a step up transformer (Fig. 15.20 a). Similarly if $N_s < N_p$, i.e., the number of turns in the secondary is less than the number in primary, then $V_s < V_p$, such transformer in which voltage across secondary is less than the primary voltage is called a step down transformer (Fig. 15.20 b).

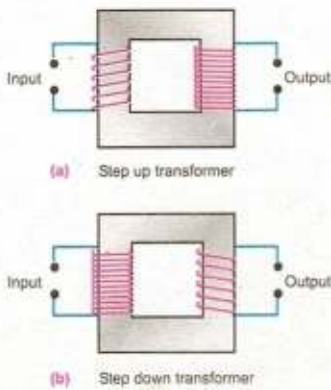

Fig. 15.20

It is important to note that the electrical power in a transformer is transformed from its primary to the secondary coil by means of changing flux. For an ideal case the power input to the primary is nearly equal to the power output from the secondary i.e.,

$$\text{Power input} = \text{Power output}$$

i.e., $V_p I_p = V_s I_s$

or $\frac{V_s}{V_p} = \frac{I_p}{I_s} \dots\dots\dots (15.33)$

I_p is the current in the primary and I_s in the secondary. The currents are thus inversely proportional to the respective voltages. Therefore, in a step up transformer when the voltage across the secondary is raised, the value of current is reduced. This is the principle behind its use in the electric supply network where transformer increases the voltage and reduces the current so that it can be transmitted over long distances without much power loss. When current I passes through a resistance R , the power loss due to heating effect is I^2R . Suppose R is the resistance of transmission line. In order to minimize the loss during transmission, it is not possible to reduce R because it requires the use of thick copper wire which becomes highly uneconomical. The purpose is well served by reducing I . At the generating power station the voltage is stepped up to several thousand of volts and power is transmitted at low current to long distances without much loss. Step down transformers then decrease the voltage to a safe value at the end of line where the consumer of electric power is located. Inside a house a transformer may be used to step down the voltage from 250 volts to 9 volts for ringing bell or operating a transistor radio. Transformers with several secondaries are used in television and radio receivers where several different voltages are required.

Only in an ideal transformer the output power is nearly equal to the input power. But in an actual transformer, this is not the case. The output is always less than input due to power losses. There are two main causes of power loss, namely eddy currents and magnetic hysteresis.

In order to enhance the magnetic flux, the primary and secondary coils of the transformer are wound on soft iron core. The flux generated by the coils also passes through the core. As magnetic flux changes through a solid conductor, induced currents are set up in closed paths in the body of the

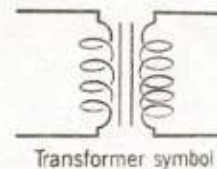

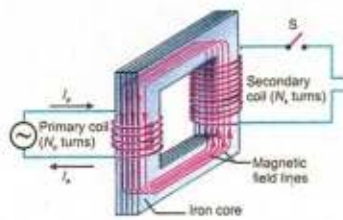

Fig. 15.21

conductor. These induced currents are set up in a direction perpendicular to the flux and are known as eddy currents. It results in power dissipation and heating of the core material. In order to minimize the power loss due to flow of these currents, the core is laminated with insulation in between the layers of laminations which stops the flow of eddy currents (Fig. 15.21). Hysteresis loss is the energy expended to magnetize and demagnetize the core material in each cycle of the A.C.

Due to these power losses, a transformer is far from being an ideal. Its output power is always less than its input power. The efficiency of a transformer is defined as

$$E = \frac{\text{output power}}{\text{input power}} \times 100$$

In order to improve the efficiency, care should be exercised, to minimize all the power losses. For example core should be assembled from the laminated sheets of a material whose hysteresis loop area is very small. The insulation between lamination sheets should be perfect so as to stop the flow of eddy currents. The resistance of the primary and secondary coils should be kept to a minimum. As power transfer from primary to secondary takes place through flux linkages, so the primary and secondary coils should be wound in such a way that flux coupling between them is maximum.

Example 15.8: The turns ratios of a step up transformer is 50. A current of 20 A is passed through its primary coil at 220 volts. Obtain the value of the voltage and current in the secondary coil assuming the transformer to be ideal one.

Solution:

$$\frac{N_s}{N_p} = 50 \quad , \quad I_p = 20 \text{ A}$$

$$V_p = 220 \text{ V} \quad V_s = ? \quad I_s = ?$$

Using the equation $\frac{V_s}{V_p} = \frac{I_p}{I_s}$ we get $\frac{V_s}{220} = 50$

Voltage in the secondary coil = $V_s = 220 \times 50 = 1100$ volts

$$I_s = \frac{V_p}{V_s} \times I_p = \frac{1}{50} \times 20 = 0.4 \text{ A}$$

SUMMARY

- An emf is set up in a conductor when it moves across a magnetic field. It is called an induced emf.
- The emf induced by the motion of a conductor across a magnetic field is called motional emf.
- Magnitude of motional emf in a rod of length L moving with velocity v across a magnetic field of strength B making θ with it is $\epsilon = vBL\sin\theta$
- Faraday's law states that the emf induced in a conducting coil of N loops is equal to the negative of the rate at which the magnetic flux through the coil is changing with time.
- The Lenz's law states that the direction of the induced current is always so as to oppose the change which causes the current.
- The phenomenon in which a changing current in one coil induces an emf in another coil is called the mutual induction.
- One henry is the mutual inductance of that pair of coils in which a change of current of one ampere per second in the primary causes an induced emf of one volt in the secondary.
- The phenomenon in which a changing current in a coil induces an emf in itself is called self induction.
- A current generator is a device that converts mechanical energy into electrical energy.
- The emf produced in a generator is $\epsilon = N\omega AB \sin(\omega t)$ or $\epsilon = \epsilon_0 \sin(2\pi ft)$.
- A motor is a device, which converts electrical energy into mechanical energy.
- The induced emf in a motor opposes the emf running the motor. This induced emf is called the back emf of the motor.

QUESTIONS

- 15.1 Does the induced emf in a circuit depend on the resistance of the circuit? Does the induced current depend on the resistance of the circuit?
- 15.2 A square loop of wire is moving through a uniform magnetic field. The normal to the loop is oriented parallel to the magnetic field. Is a emf induced in the loop? Give a reason for your answer.
- 15.3 A light metallic ring is released from above into a vertical bar magnet (Fig. Q.15.3). Viewed for above, does the current flow clockwise or anticlockwise in the ring?



Fig. Q.15.3

- 15.4 What is the direction of the current through resistor R in Fig.Q.15.4?. When switch S is
 (a) closed
 (b) opened.

Fig. Q. 15.4

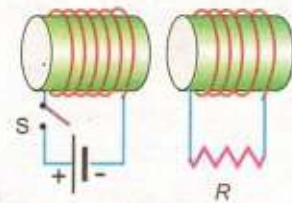

- 15.5 Does the induced emf always act to decrease the magnetic flux through a circuit?

- 15.6 When the switch in the circuit is closed a current is established in the coil and the metal ring jumps upward (Fig.Q.15.6). Why? Describe what would happen to the ring if the battery polarity were reversed?

Fig. Q. 15.6

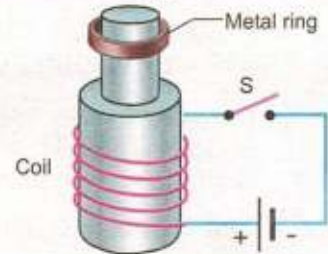

- 15.7 The Fig.Q.15.7 shows a coil of wire in the xy plane with a magnetic field directed along the y - axis. Around which of the three coordinate axes should the coil be rotated in order to generate an emf and a current in the coil?

Fig. Q. 15.7

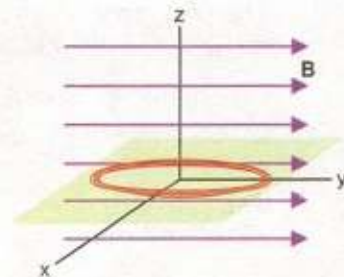

- 15.8 How would you position a flat loop of wire in a changing magnetic field so that there is no emf induced in the loop?
- 15.9 In a certain region the earth's magnetic field point vertically down. When a plane flies due north, which wingtip is positively charged?
- 15.10 Show that ϵ and $\frac{\Delta\Phi}{\Delta t}$ have the same units.
- 15.11 When an electric motor, such as an electric drill, is being used, does it also act as a generator? If so what is the consequence of this?
- 15.12 Can a D.C motor be turned into a D.C generator? What changes are required to be done?
- 15.13 Is it possible to change both the area of the loop and the magnetic field passing through the loop and still not have an induced emf in the loop?
- 15.14 Can an electric motor be used to drive an electric generator with the output from the generator being used to operate the motor?
- 15.15 A suspended magnet is oscillating freely in a horizontal plane. The oscillations are strongly damped when a metal plate is placed under the magnet. Explain why this occurs?

- 15.16 Four unmarked wires emerge from a transformer. What steps would you take to determine the turns ratio?
- 15.17 a) Can a step-up transformer increase the power level?
b) In a transformer, there is no transfer of charge from the primary to the secondary. How is, then the power transferred?
- 15.18 When the primary of a transformer is connected to a.c mains the current in it
a) is very small if the secondary circuit is open, but
b) increases when the secondary circuit is closed. Explain these facts.

PROBLEMS

- 15.1 An emf of 0.45 V is induced between the ends of a metal bar moving through a magnetic field of 0.22 T. What field strength would be needed to produce an emf of 1.5 V between the ends of the bar, assuming that all other factors remain the same?
(Ans: 0.73 T)
- 15.2 The flux density B in a region between the pole faces of a horse-shoe magnet is 0.5 Wbm^{-2} directed vertically downward. Find the emf induced in a straight wire 5.0 cm long, perpendicular to B when it is moved in a direction at an angle of 60° with the horizontal with a speed of 100 cms^{-1} .
(Ans: $1.25 \times 10^{-2} \text{ V}$)
- 15.3 A coil of wire has 10 loops. Each loop has an area of $1.5 \times 10^{-3} \text{ m}^2$. A magnetic field is perpendicular to the surface of each loop at all times. If the magnetic field is changed from 0.05 T to 0.06 T in 0.1 s, find the average emf induced in the coil during this time.
(Ans: $+1.5 \times 10^{-3} \text{ V}$)
- 15.4 A circular coil has 15 turns of radius 2 cm each. The plane of the coil lies at 40° to a uniform magnetic field of 0.2 T. If the field is increased by 0.5 T in 0.2 s, find the magnitude of the induced emf.
(Ans: $1.8 \times 10^{-2} \text{ V}$)
- 15.5 Two coils are placed side by side. An emf of 0.8 V is observed in one coil when the current is changing at the rate of 200 As^{-1} in the other coil. What is the mutual inductance of the coils?
(Ans: 4 mH)
- 15.6 A pair of adjacent coils has a mutual inductance of 0.75 H. If the current in the primary changes from 0 to 10 A in 0.025 s, what is the average induced emf in the secondary? What is the change in flux in it if the secondary has 500 turns?
(Ans: 300 V, $1.5 \times 10^{-2} \text{ Wb}$)
- 15.7 A solenoid has 250 turns and its self inductance is 2.4 mH. What is the flux through each turn when the current is 2 A? What is the induced emf when the current changes at 20 As^{-1} ?
(Ans: $1.92 \times 10^{-6} \text{ Wb}$, 48 mV)
- 15.8 A solenoid of length 8.0 cm and cross sectional area 0.5 cm^2 has 520 turns. Find the self inductance of the solenoid when the core is air. If the current in the solenoid increases through 1.5 A in 0.2 s, find the magnitude of induced emf in it.
($\mu_0 = 4\pi \times 10^{-7} \text{ WbA}^{-1}\text{m}^{-1}$)
(Ans: $1.6 \times 10^{-3} \text{ V}$, $2.12 \times 10^{-4} \text{ H}$)

- 15.9 When current through a coil changes from 100 mA to 200 mA in 0.005 s, an induced emf of 40 mV is produced in the coil. (a) What is the self inductance of the coil?
(b) Find the increase in the energy stored in the coil. (Ans: 2 mH, 0.03 mJ)
- 15.10 Like any field, the earth's magnetic field stores energy. Find the magnetic energy stored in a space where strength of earth's field is 7×10^{-5} T, if the space occupies an area of 10×10^8 m² and has a height of 750 m. (Ans: 1.46×10^9 J)
- 15.11 A square coil of side 16 cm has 200 turns and rotates in a uniform magnetic field of magnitude 0.05 T. If the peak emf is 12 V, what is the angular velocity of the coil (Ans: 47 rad s⁻¹)
- 15.12 A generator has a rectangular coil consisting of 360 turns. The coil rotates at 420 rev per min in 0.14 T magnetic field. The peak value of emf produced by the generator is 50 V. if the coil is 5.0 cm wide, find the length of the side of the coil. (Ans: 45 cm)
- 15.13 It is desired to make an a.c generator that can produce an emf of maximum value 5kV with 50 Hz frequency. A coil of area 1 m² having 200 turns is used as armature. What should be the magnitude of the magnetic field in which the coil rotates? (Ans: 0.08 T)
- 15.14 The back emf in a motor is 120 V when the motor is turning at 1680 rev per min. What is the back emf when the motor turns 3360 rev per min? (Ans: 240 V)
- 15.15 A D.C motor operates at 240 V and has a resistance of 0.5 Ω . When the motor is running at normal speed, the armature current is 15 A. Find the back emf in the armature. (Ans: 232.5 V)
- 15.16 A copper ring has a radius of 4.0 cm and resistance of 1.0 m Ω . A magnetic field is applied over the ring, perpendicular to its plane. If the magnetic field increases from 0.2 T to 0.4 T in a time interval of 5×10^{-3} s, what is the current in the ring during this interval? (Ans: 201 A)
- 15.17 A coil of 10 turns and 35 cm² area is in a perpendicular magnetic field of 0.5 T. The coil is pulled out of the field in 1.0 s. Find the induced emf in the coil as it is pulled out of the field. (Ans: 1.75×10^{-2} V)
- 15.18 An ideal step down transformer is connected to main supply of 240 V. It is desired to operate a 12 V, 30 W lamp. Find the current in the primary and the transformation ratio? (Ans: 0.125 A, 1/20)